

MasterFit

A

Convenient one-stop installation

SIZES 72" - 115"

An integrated in-ceiling screen solution designed for installation from within the ceiling. Uses a custom designed aluminium box for a lightweight solution, yet still provides structural integrity.



MasterFit

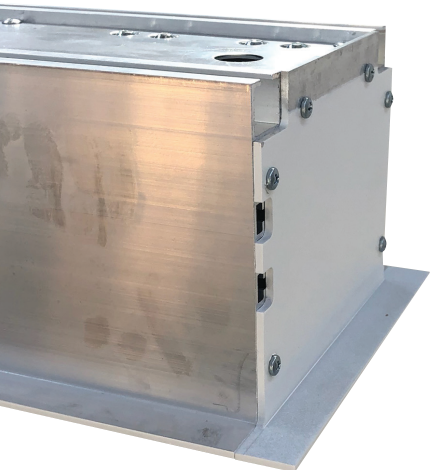

Market Segments:



Home
Entertainment



Education



Government



Defense



Boardroom



Corporate

Benefits include:

- Fully integrated with IR
- 12V trigger
- Contact closure
- Option to upgrade to Connect IP control

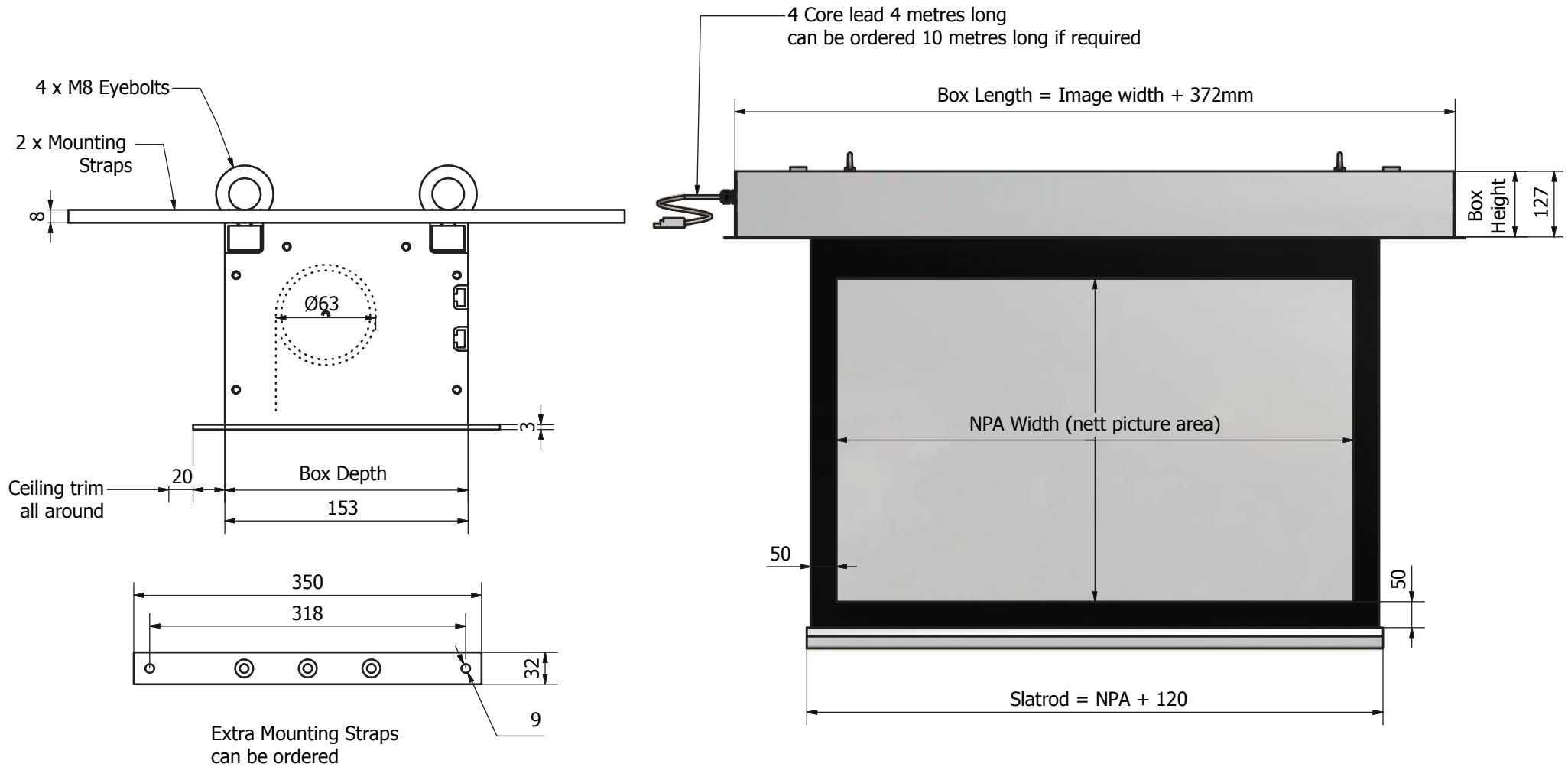

Manufacturing tolerance +/- 5mm on in ceiling box and slatrod
 All dimensions are in (mm)
 Always allow for removal of screen for servicing.

The Concept, Design and Details in this drawing are the property of Screen Technics with whom the copyright resides. They may not be reproduced without written permission of Screen Technics.

Date
16/07/19

Part Number
MFxxxxx-A

Rev
02

Product Features

- An integrated in ceiling screen solution designed for a one-stop installation from within the ceiling space
- Utilises a custom designed aluminium box for lightweight solution but still providing structural integrity
- Connect Infra red and dry contact control as standard - upgradeable to Connect IP control
- Custom sizes available

ITEM NO	INCH DIAGONAL	IMAGE SIZE mm	FORMAT	BOX LENGTH mm	BOX HEIGHT mm	BOX DEPTH mm	WEIGHT kg
MF07219-A	72"	1100 x 1465	Video 4:3	1857	127	153	28.0
MF08419-A	84"	1280 x 1705	Video 4:3	2097	127	153	31.0
MF09619-A	96"	1465 x 1950	Video 4:3	2342	127	153	33.0
MF10019-A	100"	1525 x 2035	Video 4:3	2427	127	153	34.0
MF11019-A	110"	1675 x 2235	Video 4:3	2627	127	153	36.0
MF11519-A	115"	1755 x 2340	Video 4:3	2732	127	153	38.0
MF07229-A	72"	895 x 1595	HDTV 16:9	1987	127	153	29.0
MF08429-A	84"	1045 x 1860	HDTV 16:9	2252	127	153	32.0
MF09229-A	92"	1145 x 2035	HDTV 16:9	2427	127	153	34.0
MF09629-A	96"	1195 x 2125	HDTV 16:9	2517	127	153	35.0
MF10029-A	100"	1245 x 2215	HDTV 16:9	2607	127	153	36.0
MF11029-A	110"	1370 x 2435	HDTV 16:9	2827	127	153	38.0
MF11529-A	115"	1430 x 2545	HDTV 16:9	2937	127	153	39.0
MF07269-A	72"	970 x 1550	16:10	1942	127	153	29.0
MF08469-A	84"	1130 x 1810	16:10	2202	127	153	31.0
MF09269-A	92"	1240 x 1980	16:10	2372	127	153	33.0
MF09669-A	96"	1295 x 2070	16:10	2462	127	153	34.0
MF10069-A	100"	1345 x 2155	16:10	2547	127	153	35.0
MF11069-A	110"	1480 x 2370	16:10	2762	127	153	38.0
MF11569-A	115"	1550 x 2480	16:10	2872	127	153	39.0

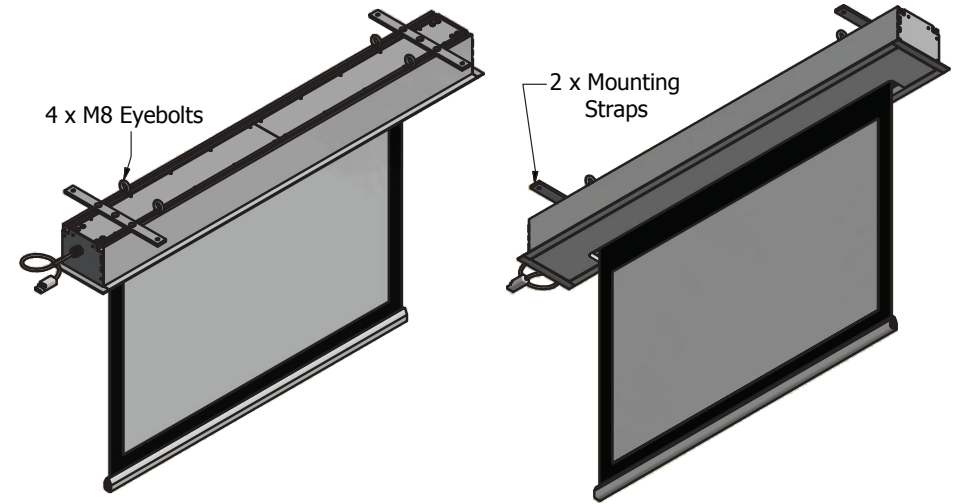

ARCHITECTS SPECIFICATION

The projection screen shall be an Australian made Screen Technics MasterFit Type A model _____with Unity White Black Backed Fibreglass surface and shall be located where indicated on the plans.
Installation shall be done in accordance with the manufacturer’s instructions



Manufacturing tolerance +/- 5mm on in ceiling box and slatrod
All dimensions are in (mm)
Always allow for removal of screen for servicing.

AUSTRALIA

22-24 Suttor Road

Moss Vale NSW 2577

+61 2 4869 2100

screeentechnics.com.au • info@screeentechnics.com.au

NEW ZEALAND

44 Mahana Road

Te Rapa, Hamilton

+0800 022 821