

MODEL NUMBER	TOTAL HEIGHT (mm)	COLOUR	MAX LOAD (kg)	DIMENSIONS (mm)		
				W	D	H
142000AW	120	White	30.0	320	320	120
142000AB	120	Black	30.0	320	320	120
142000BW	300	White	30.0	320	320	300
142000BB	300	Black	30.0	320	320	300
142000CW	600	White	30.0	320	320	600
142000CB	600	Black	30.0	320	320	600
142000DW	900	White	30.0	320	320	900
142000DB	900	Black	30.0	320	320	900
142000EW	1200	White	30.0	320	320	1200
142000EB	1200	Black	30.0	320	320	1200
142000GW	1500	White	30.0	320	320	1500
142000GB	1500	Black	30.0	320	320	1500
142000HW	1800	White	30.0	320	320	1800
142000HB	1800	Black	30.0	320	320	1800
142000JW	2100	White	30.0	320	320	2100
142000JB	2100	Black	30.0	320	320	2100
142000KW	2400	White	30.0	320	320	2400
142000KB	2400	Black	30.0	320	320	2400

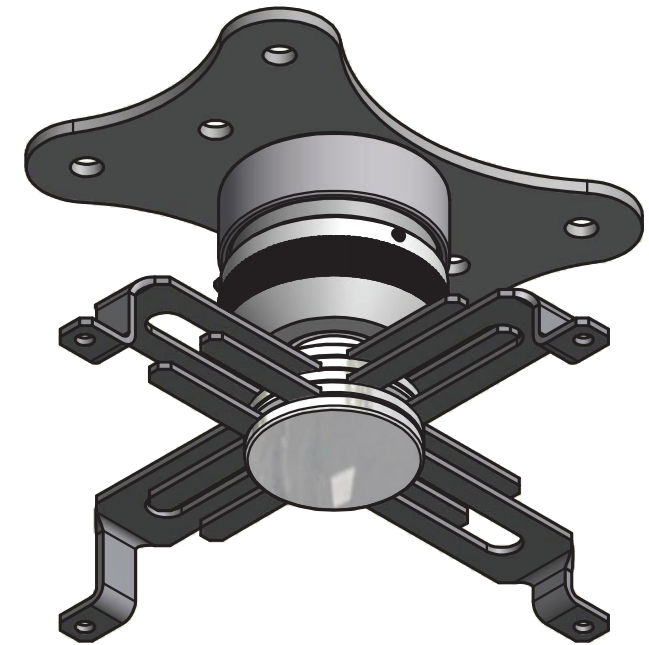
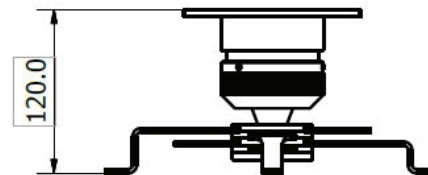
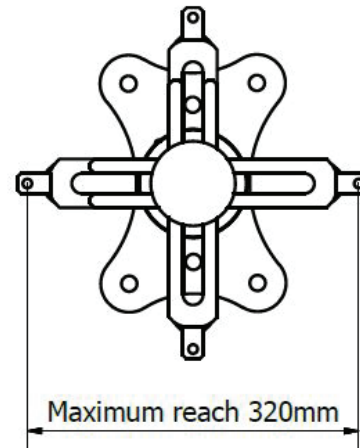

A universal spider mount system with a build quality second to none in the AV industry

ARCHITECTS SPECIFICATION

The projector bracket / accessories shall be an Australian made Screen Technics bracket model _____ and shall be located where indicated on the plans.
Installation shall be done in accordance with the manufacturer's instructions



The Concept, Design and Details in this drawing are the property of Screen Technics with whom the copyright resides. They may not be reproduced without written permission of Screen Technics.

Date	Part Number	Rev
16/07/2019	142000A	02

AUSTRALIA

22-24 Suttor Road
Moss Vale NSW 2577
+61 2 4869 2100

NEW ZEALAND

44 Mahana Road
Te Rapa, Hamilton
+0800 022 821

screeentechnics.com.au • info@screeentechnics.com.au